

A Generalized Framework for Analyzing Time-Space Switched Optical Networks

R. Srinivasan and Arun K. Somani
Dependable Computing & Networking Laboratory
Department of Electrical and Computer Engineering
Iowa State University, Ames, IA 50011
E-Mail: {rsrini, arun}@iastate.edu

Abstract—Recent advances in photonic switching have paved the way for realizing all-optical time switched networks. The current technology of Wavelength Division Multiplexing (WDM) offers bandwidth granularity that match peak electronic transmission speed by dividing the fiber bandwidth into multiple wavelengths. However, the bandwidth of a single wavelength is too large for certain traffic. Time Division Multiplexing (TDM) allows multiple traffic streams to share the bandwidth of a wavelength efficiently. While introducing wavelength converters and time slot interchangers improve network blocking performance, it is often of interest to know the incremental benefits offered by every additional stage of switching.

As all-optical networks in future are expected to employ heterogeneous switching architectures, it is necessary to have generalized network model that allows to study these networks under a unified framework. In this paper, a network model, called Trunk Switched Network (TSN), is proposed to facilitate modeling and analysis of such networks. An analytical model for evaluating the blocking performance of a class of TSN's has also been developed. Using the analytical model, it is shown that a significant performance improvement is obtained with a time-space switch with no wavelength conversion at each node in a multi-wavelength TDM switched network.

Keywords—Optical networks, WDM/TDM switching, Performance modeling

I. INTRODUCTION

WAVELENGTH DIVISION MULTIPLEXING (WDM) has emerged as an efficient mechanism for information transport in all-optical networks. WDM divides the available fiber bandwidth into a set of wavelengths (WDM channels). Early research in optical networks focused on single-fiber multi-wavelength wavelength-routed networks. Nodes in these networks can switch wavelengths across ports. Wavelength Converter (WC) is a device that allows optical signal on one wavelength to be converted into another wavelength. If wavelength converters are not available, a call arriving at a node on a certain wavelength has to be switched to the same wavelength at the output. Although wavelength converters improve network blocking performance, the high cost of wavelength converters have made it impractical to employ full-wavelength conversion at all nodes. The role of wavelength converters in wavelength-routed networks has been studied in [1], [2], [3], [4], [5], and [6]. The role of sparse-wavelength conversion, where only a few nodes in the network have full-wavelength conversion capability, has been analyzed in [6]. The effect of limited-wavelength conversion, where a given input wavelength can be converted into a set of, but not all, output wavelengths has been studied in [7] and [8]. Multi-fiber multi-wavelength wavelength-routed

networks have been shown to offer blocking performance similar to that of networks that employ limited- or sparse-wavelength conversion in [9], [10], and [11].

WDM offers bandwidth granularity close to the peak electronic transmission speed. The bandwidth of a single wavelength is too large for certain traffic requirements. While some traffic may have a requirement of fractional wavelength, another traffic that is already using a full-wavelength might want to expand its capacity, but not want to pay for an entire new wavelength. This motivates the need for providing fractional wavelength capacity to the network traffic.

Provisioning fractional wavelength capacity is achieved by dividing a wavelength into time slots and multiplexing traffic on the wavelength. The resulting optical time division multiplexed networks (OTDM networks) can be classified into two categories [12]: dedicated-wavelength TDM (DW-TDM) networks and shared-wavelength TDM (SW-TDM) networks. In DW-TDM networks, each source-destination pair is connected by a *lightpath*, where a lightpath is defined as an all-optical connection between two nodes. Calls between the source and destination are multiplexed on the lightpath. If the bandwidth required by a new call at a node is not available on any of the existing lightpaths to the destination, a new lightpath to the destination is established. On the other hand, in SW-TDM networks, if a call cannot be accommodated on an existing lightpath to the destination, it is allowed to be multiplexed onto an existing lightpath to an intermediate node. The call is then switched from the intermediate node to the final destination either directly or through other nodes. However, if none of the existing lightpaths from the node can accommodate the call, a new lightpath to the destination is established.

The performance of SW-TDM networks depend on efficient merging of the fractional wavelength requirements of the nodes into a full or almost-full wavelength requirement. This merging of traffic from different source-destination pairs is called *traffic grooming*. Nodes that can groom traffic are capable of multiplexing/de-multiplexing lower rate traffic onto a wavelength and switching them from one lightpath to another. The grooming of traffic can be either static or dynamic. In static traffic grooming, the source-destination pairs whose requirements are combined are pre-determined. In dynamic traffic grooming, connection requests from different source-destination pairs are combined depending on the existing lightpaths at the time of request arrival.

Recent advances optical switching technology, as in [13],

The research reported in this paper is funded in part by the National Science Foundation under grant ANI-9973012, Defense Advanced Research Projects Agency under contract N66001-00-1-8949, and David C. Nicholas Professorship Fund at Iowa State University.

[14], and [15], have shown the possibility of realizing fast all-optical switches with switching time less than a nanosecond. The use of such fast switches along with fiber delay lines as time-slot interchangers [16], [17] have opened up the possibility to realize optical time switched networks. These networks will be referred to as *OTDM Switched* networks in the rest of this paper. Connection between a source and destination in an OTDM switched network is realized by assigning a time slot on every link of a chosen path, with the constraint that the slot on one link can be switched to the next link by the intermediate node. OTDM switched network can be considered as a special case of SW-TDM network, where all the nodes in network are capable of grooming traffic and lightpaths to the neighboring nodes are established permanently. The bandwidth granularity offered by an OTDM network is determined by the duration of a time slot which, in turn, depends on the speed at which the switching can be accomplished. In general, an OTDM switched network is a multi-fiber, multi-wavelength, TDM-switched all-optical network.

Routing individual slot dynamically requires information processing in optical domain. However, the technology in optical processing and storage has not matured to achieve run-time routing decisions at high-speeds. Therefore, OTDM switched networks are expected to be *circuit-switched* in nature. As the information in a time slot is not read by an intermediate node at run-time, the switching employed here is also referred to as *transparent optical switching*.

In [12], a single-fiber multi-wavelength TDM-switched network has been analyzed for blocking performance, as an extension of the link-independence model proposed for wavelength-routed network in [3] and [4]. The equivalence of single-fiber multi-wavelength TDM-switched network to multi-fiber multi-wavelength wavelength-routed networks has been shown in [10] and [11]. A wavelength-routed network is a special case of OTDM switched network when every wavelength has one time slot.

It is well understood that all-optical networks in future would comprise of nodes that employ heterogeneous switching architectures, like wavelength-routing switch, OTDM switch with or without wavelength conversion, etc. The existing work on the analysis of optical networks in literature study the role of switching functionalities, like wavelength conversion, time slot interchange, etc. in isolation. In other words, the network model that is considered has nodes that either have or do not have the specific functionality that is studied. However, in order to analyze a network with nodes employing heterogeneous switching architectures, it is necessary to have a generalized network model that would enable the modeling of realistic networks and evaluate them under a unified framework. In this paper, a network model, called Trunk Switched Network (TSN), is proposed to facilitate modeling and analysis of such networks.

The paper is organized as follows: Section II describes OTDM switched network architectures. Section III introduces the concept of a trunk switched network and modeling of an OTDM switched network as a TSN. An analytical model for evaluating the blocking performance of a class of TSN's is developed in Section IV. A multi-wavelength TDM switched network is analyzed using this framework and the network blocking

performance is compared against three different switch architectures. Section V discusses the performance results obtained using the analytical model. Section VI concludes the paper.

II. OTDM SWITCHED NETWORKS

An OTDM switched network consists of switching nodes interconnected by one or more optical fibers. Each fiber carries a certain number of wavelengths. Each wavelength is divided into frames which are further sub-divided into time slots. Let L denote the number of links at a node, F denote the number of fibers per link, W denote the number of wavelengths per fiber, and T denote the number of time slots per frame on a wavelength.

Every slot within a frame can be denoted by a 4-tuple, (l, f, w, t) , where $1 \leq l \leq L$, $1 \leq f \leq F$, $1 \leq w \leq W$, and $1 \leq t \leq T$. For example, the tuple $(1, 1, 2, 1)$ (read from right to left) denotes first time slot in a frame on the second wavelength of the first fiber on the first link. A *channel* on a link is defined as a collection of a particular time slot across successive frames. Hence, the number of channels in a link is the same as the number of slots in a frame, $F \times W \times T$. Each channel is also represented by a 4-tuple, (l, f, w, t) , similar to the representation of a slot. It can be observed that if a frame has only one time slot, $T = 1$, an OTDM switched network reduces to a multi-fiber multi-wavelength wavelength-routed network. A switch at a node maps an input channel to an output channel. The constraints on the mapping of an input channel to an output channel is determined by the nature of the switch.

The simplest switch architecture is a space switch. In this switch, an input channel, $(l, f, w, t)_i$, could be mapped to an output channel, $(l, f, w, t)_o$, if and only if $t_i = t_o$, $w_i = w_o$, and $f_i = f_o$. With a time slot interchanger (TSI), an input channel $(l, f, w, t)_i$ could be mapped to an output channel $(l, f, w, t)_o$, where $t_i \neq t_o$, by delaying the signals. A combination of time and space switching can be employed in multiple stages to realize more permutation of space and time. If the switches do not employ wavelength conversion, then the wavelength of the input and output channels must be the same, hence $w_i = w_o$. In networks with multiple fibers connecting two nodes an input channel, $(l, f, w, t)_i$, can be mapped to an output channel $(l, f, w, t)_o$, where $f_i \neq f_o$.

III. TRUNK SWITCHED NETWORKS

A trunk switched network (TSN) consists of switching nodes interconnected by links. Each link has a set of channels. The number of channels in a link, denoted by C , is the same on all the links in the network. A node in a TSN views a link as a set of K trunks with S channels per trunk, where $KS = C$. Fig. 1 shows the node architecture in a TSN. The node has four links connected to it. Each link is viewed as a set of 4 trunks by the node. Switching at every node obeys the following two conditions:

- A full-channel interchanger (FCI) is employed at the input for every trunk, as shown in Fig. 1.
- Switching at a node obeys trunk-continuity constraint, i.e., the channels cannot be switched across trunks.

The definition of a trunk could be different across nodes. For example, one node could view a link as K_1 trunks with S_1 channels per trunk while another node could view the link as K_2

trunks with S_2 channels per trunk, where $K_1 S_1 = K_2 S_2 = C$. Fig. 2 shows two nodes in a TSN connected by a link. The input to switch from other links at the node are not shown in the figure. Fig. 2(a) shows two nodes that view the link as a set of 4 trunks. In Fig. 2(b), the first node views the link as 3 trunks while the second node views the link as 4 trunks.

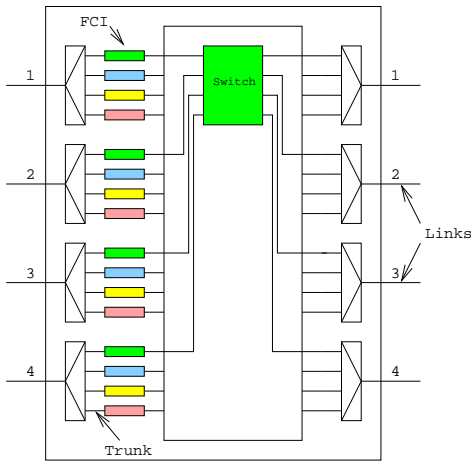

Fig. 1. Node architecture in a TSN.

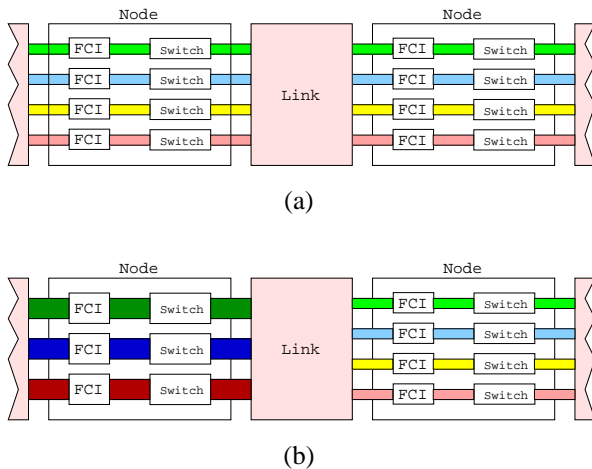

Fig. 2. Two nodes connected by a link in a TSN. (a) The link is viewed as 4 trunks by both the nodes. (b) The link is viewed as 3 and 4 trunks by the first and second node, respectively.

A TSN is said to be *homogeneous* if the collection of channels that constitute a trunk at a node is the same for all the nodes in the network. Otherwise, it is said to be *heterogeneous*. The nodes shown in Fig. 2(a) could form a part of homogeneous TSN if the channels that constitute a trunk for the two nodes are the same as that at the rest of the nodes. Note that two nodes could view a link as a set of K trunks, but could still be heterogeneous if the channels within the trunks are not identical. On the other hand, the nodes shown in Fig. 2(b) form a part of a heterogeneous TSN. Although the trunk definition is the same for all the nodes in a homogeneous TSN, the switching employed within a trunk could be different at different nodes. As channels cannot be switched across trunks at a node, by the definition of

a trunk at the node, a homogeneous TSN imposes an *end-to-end trunk-continuity constraint* on the connections.

A trunk on a link, as viewed by a node, is said to be *busy* if all the channels in the trunk are busy, otherwise it is said to be *free*. Fig. 3 shows a node in a TSN and one of its input and output links. The link is viewed as a set of 4 trunks by the node. The number of channels busy on a trunk at the input of a node is the same as the number of channels busy on the trunk at the input to the switch at the node. However, the distribution of the busy channels on the trunk at the input of the node is different from that at the input of the switch. The number of trunks busy at the input of a node is the same as the number of trunks busy at the input of the switch at that node.

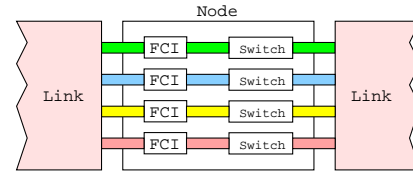

Fig. 3. Two links connected by a node.

Consider a trunk on a two-link path (a trunk at the input and output of the node shown in Fig. 3). The trunk is said to be *available* on the two-link path if there is a free channel in the trunk on the first link that can be switched by the node to a free channel in the second link, subjected to the constraints of the switch. Hence, if a trunk is free on two links individually, it does not necessarily imply that the trunk is available on the two-link path. For example, consider a scenario when the switch at the node shown in Fig. 3 is a space-only switch¹. Hence channel continuity constraint is imposed by the switch. Also, assume that there are 5 channels per trunk. Let channels 1 and 2 on a trunk be busy at the input of the switch and channels 3, 4, and 5 be busy at the output of the switch. The free channels at the input of the switch (hence, at the node) cannot be switched to the free channels at output of the switch. Hence, the trunk is not available on the two-link path.

A connection between a source and destination is established over a path. Each path consists of a set of links and the number of links in a path denotes the length of the path. The selection of a path in the network could be either static or dynamic. A connection between a source and a destination over a path is realized by assigning a channel on each link on the path such that every node on the path can switch the channel assigned on its input link to the channel assigned on its output link. A call is said to be blocked if such a channel assignment is not possible.

A. Modeling an OTDM switched network as a TSN

An OTDM switched network can be modeled as a TSN. Although a trunk can be defined as an arbitrary collection of channels, only a few make a meaningful trunk definition in reality. A few possible trunk definitions at a node are discussed here with an example.

¹ Although the switch at a node is space-only the node behaves like a channel-space switch.

Consider a link with one fiber, 4 wavelengths per fiber and 5 time slots per wavelength ($F = 1, W = 4, T = 5$). Each slot on a link l is denoted by a 4-tuple tuple (l, f, w, t) , where $f = 1, 1 \leq w \leq 4$, and $1 \leq t \leq 5$.

- If time slot interchange and wavelength conversion are not permitted, then, for any link l , each wavelength and time slot combination can be treated as a trunk, i.e., $Tr_{(w,t)} = \{(l, 1, w, t)\}$. In this case, a link is viewed as WT trunks with one channel per trunk.
- If time slot interchange is permitted, but not wavelength conversion, then for a given link l , every wavelength can be considered as a trunk, i.e., $Tr_w = \{(l, 1, w, t) | 1 \leq t \leq T\}$. Thus, a link is viewed as W trunks with T channels per trunk. Note that, the switch at a node need not provide full-permutation switching capability.
- If full-wavelength conversion is permitted, but not time slot interchange, then for a given link l , a time slot on all the wavelengths can be grouped to form a trunk, i.e., $Tr_t = \{(l, 1, w, t) | 1 \leq w \leq W\}$. Thus, a link is viewed as T trunks with W channels per trunk.
- If both full-wavelength conversion and time slot interchange are permitted, then the entire link is treated as one trunk with WT channels.

A multi-fiber multi-wavelength wavelength-routed network with F fibers and W wavelengths with no wavelength conversion can be viewed as W trunks with F channels per trunk. If full-wavelength conversion is available, then a link can be viewed as a single trunk with FW channels. However, networks that employ limited-wavelength conversion, as defined in [7] and [8], cannot be modeled as a TSN, as a full-permutation wavelength-conversion is not employed.

IV. ANALYSIS OF TRUNK SWITCHED NETWORKS

Consider a trunk switched network with N nodes. An analytical model for evaluating the blocking performance is developed in this section based on the following assumptions:

- The call arrival at every node follows a Poisson process with rate λ_n and is equally likely to be destined to any other node. The choice of Poisson traffic is to keep the analysis tractable.
- The traffic is assumed to be point-to-point (no broadcast or multi-cast traffic is considered).
- The bandwidth requirement of every call is assumed to be of one channel capacity.
- The holding time of every call follows an exponential distribution with mean $\frac{1}{\mu}$. The Erlang load offered by a node is $\rho_n = \frac{\lambda_n}{\mu}$.
- The path selection is pre-determined (fixed-path routing), eg: shortest-path.
- Blocked calls are not re-attempted.
- A call is assigned a channel randomly from a set of available channels.

The network blocking probability is computed as the average blocking probability experienced over different path lengths. Consider a z -link path model as shown in Fig. 4.

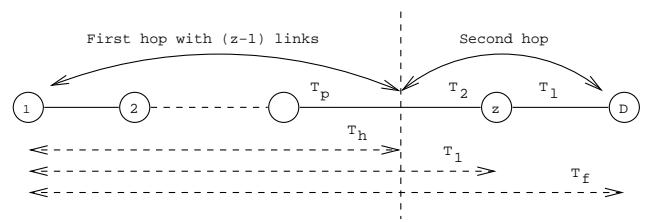

Fig. 4. A z -link path model

Let $P_z(T_f)$ denote the probability of T_f trunks being available on a z -link path as viewed by the last node on the path² (node z). The definition of the trunk is as viewed by the node denoted by the suffix for P . $P_z(T_f = 0)$ denotes the blocking probability over the z -link path. The ensemble average of the network blocking probability, denoted by P_b , is obtained as:

$$P_b = \sum_{z=1}^{N-1} P_z(T_f = 0)P(z) \quad (1)$$

where $P(z)$ denotes the probability of selecting a z -link path. $P(z)$ depends on the network topology and routing strategy employed in the network, and can be easily computed for most regular network topologies and routing strategies.

Let $P_z(T_f, T_l)$ denote the probability of T_f trunks being available on a z -link path with T_l trunks free on the last link. It can be seen that the last link should have at-least T_f trunks free, therefore $T_l \geq T_f$. $P_z(T_f)$ can then be written as:

$$P_z(T_f) = \sum_{T_l=T_f}^{K_z} P_z(T_f, T_l) \quad (2)$$

where K_z denotes the number trunks in the link as viewed by node z .

A z -link path can be analyzed as a two-hop path by considering the first $z - 1$ links as the first hop and last two links as the second hop, as shown in Fig. 4. Let T_h and T_p denote the number of trunks available on the first hop and that which are free on the last link of the first hop (link $z - 1$) as viewed by the last node on the first hop (node $z - 1$). Let T_1 and T_2 denote the number of trunks free on the first hop and number of trunks free on the last link of the first hop as seen by the node in the second hop (node z). $P_z(T_f, T_l)$ can then be recursively computed as:

$$P_z(T_f, T_l) = \sum_{T_h=0}^{K_{z-1}} \sum_{T_p=T_h}^{K_{z-1}} \sum_{T_1=T_f}^{K_z} \sum_{T_2=T_1}^{K_z} P_{z-1}(T_h, T_p) P(T_1, T_2 | T_h, T_p) P(T_f, T_l | T_1, T_2) \quad (3)$$

where $P(T_f, T_l | T_1, T_2)$ denotes the probability of T_f trunks being available on the second hop with T_l trunks free on the last link of the second hop given that T_1 trunks are available on the first hop with T_2 trunks free at the input to the node on the second hop. $P(T_1, T_2 | T_h, T_p)$ denotes the probability that the number of trunks available on the first hop and number of trunks free on the last link of the first hop as viewed by the node in the second hop are T_1 and T_2 , respectively, given that the trunk availability as viewed by the last node on the first hop is T_h and T_p .

²The destination is not considered as the last node in the path.

For homogeneous TSN's, $P(T_1, T_2|T_h, T_p)$ is defined as:

$$P(T_1, T_2|T_h, T_p) = \begin{cases} 1 & \text{if } T_h = T_1 \text{ and } T_p = T_2 \\ 0 & \text{otherwise} \end{cases} \quad (4)$$

For a homogeneous TSN, Eqn. (3), therefore, reduces to:

$$P_z(T_f, T_l) = \sum_{T_h=T_f}^K \sum_{T_p=T_h}^K P_{z-1}(T_h, T_p) P(T_f, T_l|T_h, T_p) \quad (5)$$

where K denotes the number of trunks in a link as viewed by the nodes in the network. The computation of $P(T_1, T_2|T_h, T_p)$ for different trunk definitions is currently being studied by the authors. Hence, the scope of the analysis presented in this section is limited to homogeneous TSN's.

The starting point of the recursion, for $z = 1$, is defined as:

$$P_1(T_f, T_l) = \begin{cases} P(T_l) & \text{if } T_f = T_l \\ 0 & \text{otherwise} \end{cases} \quad (6)$$

where $P(T_l)$ denotes the probability of T_l trunks being free on a link. The computation of $P(T_l)$ is discussed in Section IV-B.

$P(T_f, T_l|T_h, T_p)$ is computed by conditioning on the number of trunks free on the last link as:

$$P(T_f, T_l|T_h, T_p) = \begin{cases} P(T_f|T_h, T_p, T_l) P(T_l|T_h, T_p) & \text{if } T_h \geq T_f \\ 0 & \text{otherwise} \end{cases} \quad (7)$$

where $P(T_l|T_h, T_p)$ denotes the probability of T_l trunks being free on the last link given that T_h trunks are available on the first hop with T_p trunks free on the last link of the first hop. The number of trunks free on the last link depends on the number of trunks free on the previous links. If the correlation of traffic on a link is assumed to be only due to its previous link, then it is referred to as the *Markovian correlation*. With the assumption of Markovian correlation, $P(T_l|T_h, T_p)$ can be reduced to $P(T_l|T_p)$. Hence, Eqn. (7) can be written as:

$$P(T_f, T_l|T_h, T_p) = \begin{cases} P(T_f|T_h, T_p, T_l) P(T_l|T_p) & \text{if } T_h \geq T_f \\ 0 & \text{otherwise} \end{cases} \quad (8)$$

$P(T_f|T_h, T_p, T_l)$ denotes the probability that T_f trunks are available on the two-hop path given that T_l trunks are free on the last link and T_h trunks are available on the first hop with T_p trunks free on the last link of the first hop. $P(T_f|T_h, T_p, T_l)$ is computed by considering a two-link path as shown in Fig. 5. The number of trunks free on the first link and that which are free on the second link are denoted by T_p and T_l , respectively.

The trunk on a two-link path can be in any one of the following four states, as shown Fig. 6:

- **Case 1:** The trunk is busy on both the links. The trunk can be either partially or fully occupied by continuing calls. Let V_c denote the number of trunks busy on both the links.
- **Case 2:** The trunk is busy on the first link but not on the second.

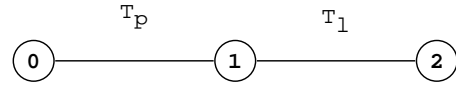

Fig. 5. A two-link path model.

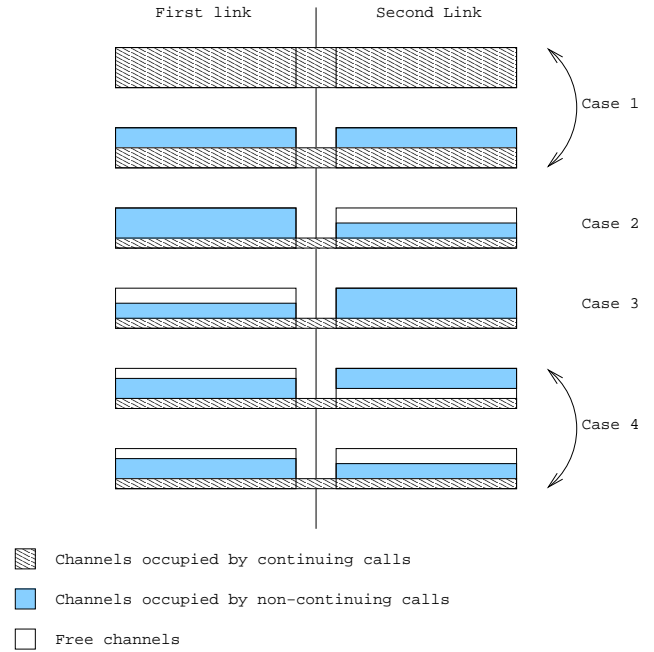

Fig. 6. A pictorial representation of the states of a trunk on a two-link path.

- **Case 3:** The trunk is busy on the second link but not on the first.
- **Case 4:** The trunk is free on both the links. Let T_b denote the number of trunks free on both the first and second links. However, this does not imply that these trunks are available on the two-link path. Let T_a ($T_a \leq T_b$) denote the number of trunks available on the two-link path. When the node connecting the two links employs a full-permutation switch, a trunk is available on the two link path if it is free on both the links. Hence, $T_a = T_b$.

Let $P(T_a, T_b|T_p, T_l)$ denote the probability that T_b trunks are free on both the first and second link with T_a among them being available on the two-link path given that T_p and T_l trunks are free on the first and second links, respectively. $P(T_f|T_h, T_p, T_l)$ can then be written as:

$$P(T_f|T_h, T_p, T_l) = \sum_{T_a=T_f}^{\min(T_p, T_l)} \sum_{T_b=T_a}^{\min(T_p, T_l)} P(T_f|T_a, T_b, T_h, T_p, T_l) P(T_a, T_b|T_p, T_l) \quad (9)$$

where $P(T_f|T_a, T_b, T_h, T_p, T_l)$ denotes the probability of T_f trunks being available on the two-hop path given that T_h trunks are available on the first hop, T_p trunks are free on the first link (the first link in the two-link model is the last link on the first hop), T_l trunks are free on the second link, T_b trunks are free on

both the first and second link and T_a among them available on the two-link path.

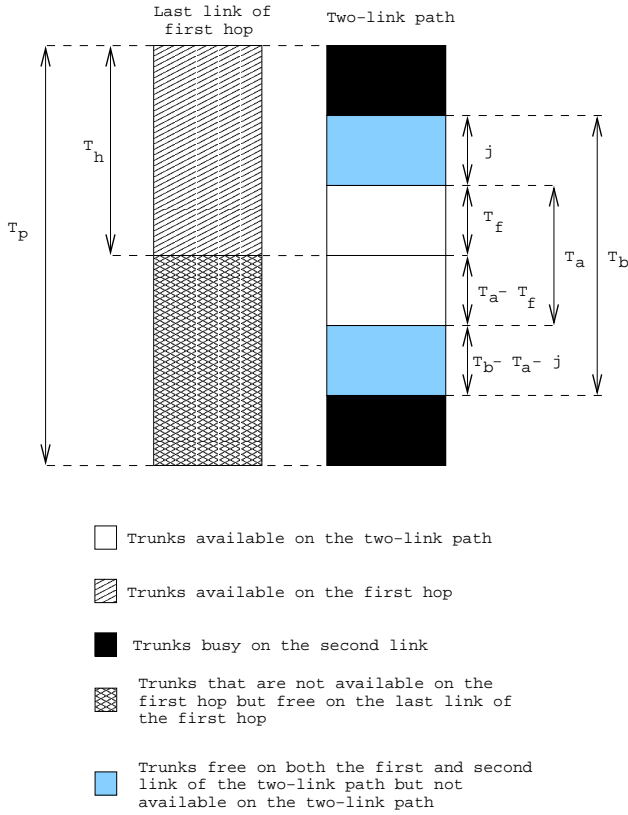

Fig. 7. A pictorial representation of the free trunks on the last link of the first hop and that on the two-link path.

Fig. 7 shows the pictorial view of the distribution of free trunks on the last link of the first hop and that of the two-link path model. From this figure, $P(T_f|T_a, T_b, T_h, T_p, T_l)$ can be computed along the lines of the following argument: Given T_p trunks are free on the last link of the first hop with T_h among them available on the first hop. Also, given T_b trunks are free on the first and second link of the two-link path with T_a among them being available on the two-link path. Among the T_a available trunks on the two-link path exactly T_f trunks overlap with the T_h trunks available on the first hop. The remaining trunks that are available on the first hop, $T_h - T_f$, are not available on the two-link path. This could occur in two cases: (1) the corresponding trunk is busy on the second link of the two-link path, or (2) the trunk is free on the second link but is not available on the two-link path (due to switching constraints). The number of trunks that satisfy the latter case is $T_b - T_a$. The required probability is computed by assuming that j of the trunks that are free on both the first and second link, but not available on the two-link path, overlap with the remaining $T_h - T_f$ available trunks of the first hop. The trunks on the second link corresponding to the remaining $T_h - T_f - j$ available trunks on the first-hop are busy. Thus, $P(T_f|T_a, T_b, T_h, T_p, T_l)$ can be written as:

$$P(T_f|T_a, T_b, T_h, T_p, T_l) = \frac{\binom{T_h}{T_f} \binom{T_p - T_h}{T_a - T_f} \sum_j \binom{T_h - T_f}{j} \binom{T_p - T_h - T_a + T_f}{T_b - T_a - j}}{\binom{T_p}{T_b} \binom{T_b}{T_a}} \quad (10)$$

where $\max(0, T_b + T_h - T_p - T_f) \leq j \leq \min(T_h - T_f, T_b - T_a)$. For the special case, when the switch at a node has full-permutation switching capability, the above equation reduces to:

$$P(T_f|T_a, T_b, T_h, T_p, T_l) = \begin{cases} \frac{\binom{T_h}{T_f} \binom{T_p - T_h}{T_a - T_f}}{\binom{T_p}{T_a}} & \text{if } T_a - T_f \leq T_p - T_h \\ 0 & \text{otherwise} \end{cases} \quad (11)$$

Also, for this case, $P(T_a, T_b|T_p, T_l) = 0$ if $T_a \neq T_b$. Hence, Eqn. (9) can be written as:

$$P(T_f|T_h, T_p, T_l) = \sum_{T_a=T_f}^{\min(T_p, T_l)} \frac{P(T_f|T_a, T_a, T_h, T_p, T_l)}{P(T_a, T_a|T_p, T_l)} \quad (12)$$

The probability values, $P(T_a, T_b|T_p, T_l)$, $P(T_l|T_p)$, and $P(T_l)$ are computed by considering a switch model as explained in the following subsections.

A. Estimation of call arrival rates on a link

Typically, the network traffic is specified in terms of offered load between node pairs. The call arrival rates at the nodes have to be translated into arrival rates at individual links in the network. The computation of blocking probability depends on the link arrival rates, and the link arrival rates, in turn, depend on the network blocking probability. However, if the blocking probability in the network is small, then its effect on the link arrival rates can be ignored. The estimation of the link arrival rates has also been discussed in [6].

Consider a network with N nodes and L links. The mean path length of a connection in the network is given by:

$$Z_{av} = \sum_{z=1}^{N-1} z P(z) \quad (13)$$

where $P(z)$ denotes the path-length distribution. The arrival rate of calls at a node is denoted by λ_n . The average link arrival rate, denoted by λ , is computed as:

$$\lambda = \frac{N \lambda_n Z_{av}}{L} \quad (14)$$

To account for link-correlation, the arrival rates of calls to a link that continue to a next link also needs to be computed. The only known parameter of the path length distribution is the mean path length, Z_{av} . Hence, the probability that a call on a given link will continue to the next link can be computed in several possible ways. One possible approach is to assume that the probability that a call on a link continues to a next link is independent of the number of links traveled by the call. Hence, at each node, the probability that a call is destined to that node

is given by $\frac{1}{Z_{av}}$. Hence, the probability that a call is continuing at a given node is $1 - \frac{1}{Z_{av}}$. Let the number of *exit links* for a path at a node be denoted by E , where *exit links* for a path is defined as those links at a node that do not connect the node to any of the previous nodes in the path. The arrival rate of calls to a link at a node that continue to a specific output link is denoted by $\lambda_c = \gamma_c \lambda$, where γ_c is the correlation factor given by:

$$\gamma_c = \left(1 - \frac{1}{Z_{av}}\right) \frac{1}{E} \quad (15)$$

B. Free trunk distribution

Consider a two-link path model as shown in Fig. 8. Let u_p , u_l , and u_c denote the number of channels busy on the first link, number of channels busy on second link, and number of channels occupied by calls that continue from the first link to the second, respectively. Note that $u_c \leq \min(u_p, u_l)$. The number of channels busy on a trunk at the input of node 1 is the same as the number of channels busy at the input of the switch (after the FCI) at the node, while the distribution of the busy channels at the input of the switch is independent of the distribution at the input of the node. Also, the state of a trunk (busy or free) at the input of the node is the same as that at the input to the switch. Therefore, the first link as referred in this subsection henceforth would correspond to the link viewed at the input of the switch.

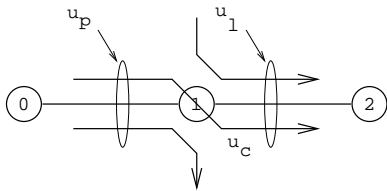

Fig. 8. Channel occupancy on a two-link path model.

Let λ_p denote the arrival rate for calls to the first link, λ_l denote the arrival rate for calls to the second link, and λ_c [$\lambda_c \leq \min(\lambda_p, \lambda_l)$] denote the arrival rate of calls to the first link that continue to the second link. If the link loads are assumed to be uniformly distributed, it follows that $\lambda_p = \lambda_l = \lambda$. The Erlang loads corresponding to the calls that occupy the first link, second link, and that which continue from the first to second can be written as, $\rho_p = \frac{\lambda_p}{\mu}$, $\rho_l = \frac{\lambda_l}{\mu}$, and $\rho_c = \frac{\lambda_c}{\mu}$, respectively.

The channel distribution on a two-link path can be characterized as a 3-dimensional Markov chain. The state-space is denoted by the 3-tuple (u_p, u_l, u_c) . The steady-state probability for the states can be computed as [18]:

$$\Pi(u_p, u_l, u_c) = \frac{\frac{(\rho_p - \rho_c)^{u_p - u_c} \rho_c^{u_c} (\rho_l - \rho_c)^{u_l - u_c}}{(u_p - u_c)! u_c! (u_l - u_c)!}}{\sum_{j=0}^{KS} \sum_{i=j}^{KS} \sum_{k=j}^{KS} \frac{(\rho_p - \rho_c)^{i-j} \rho_c^j (\rho_l - \rho_c)^{k-j}}{(i-j)! (j)! (k-j)!}} \quad (16)$$

where $0 \leq u_p \leq KS$, $0 \leq u_l \leq KS$, and $0 \leq u_c \leq \min(u_p, u_l)$.

Let V_p , V_l , and V_c denote the number of trunks busy on the first link, number of trunks busy on the second link, and number of trunks that are busy on both the first and second links, respectively. It can be observed that $V_c \leq \min(V_p, V_l)$. The number of

trunks free on both the links is given by, $T_b = K - (V_p + V_l - V_c)$. The number of trunks available on the two-link path is denoted by T_a . The state-space of the trunk distribution is captured by the 4-tuple (V_p, V_l, V_c, T_a) . The steady-state probability of the states can be computed by conditioning on the channel distribution, (u_p, u_l, u_c) as:

$$\psi(V_p, V_l, V_c, T_a) = \sum_{u_c=0}^{KS} \sum_{u_p=u_c}^{KS} \sum_{u_l=u_c}^{KS} \frac{P(V_p, V_l, V_c, T_a | u_p, u_l, u_c)}{\Pi(u_p, u_l, u_c)} \quad (17)$$

where $P(V_p, V_l, V_c, T_a | u_p, u_l, u_c)$ denotes the probability that the trunk distribution is in state (V_p, V_l, V_c, T_a) given that the channel distribution is (u_p, u_l, u_c) . The following probability values that are required to complete the analytical model, described in the previous section, can then be derived from the above steady-state probability.

$$P(T_a, T_b | T_p, T_l) = \frac{\psi(K - T_p, K - T_l, K + T_b - T_p - T_l, T_a)}{\sum_{t_a=0}^{\min(T_p, T_l)} \sum_{t_b=t_a}^{\min(T_p, T_l)} \psi(K - T_p, K - T_l, K + t_b - T_p - T_l, t_a)} \quad (18)$$

$$P(T_l | T_p) = \frac{\sum_{t_a=0}^{\min(T_p, T_l)} \sum_{t_b=0}^{\min(T_p, T_l)} \psi(K - T_p, K - T_l, K + t_b - T_p - T_l, t_a)}{\sum_{t_l=0}^{KS} \sum_{t_a=0}^{\min(T_p, t_l)} \sum_{t_b=0}^{\min(T_p, t_l)} \psi(K - T_p, K - t_l, K + t_b - T_p - t_l, t_a)} \quad (19)$$

$$P(T_l) = \sum_{t_p=0}^K \sum_{t_a=0}^{\min(t_p, T_l)} \sum_{t_b=t_a}^{\min(t_p, T_l)} \frac{\psi(K - t_p, K - T_l, K + t_b - t_p - T_l, t_a)}{\psi(K - t_p, K - T_l, K + t_b - t_p - T_l, t_a)} \quad (20)$$

The trunk occupancy probability for a given a channel distribution, is computed as:

$$P(V_p, V_l, V_c, T_a | u_p, u_c, u_l) = \frac{N_{k=K}(V_p, V_l, V_c, T_a | u_p, u_l, u_c)}{A_{k=K}(u_p, u_l, u_c)} \quad (21)$$

where $N_k(V_p, V_l, V_c, T_a | u_p, u_l, u_c)$ denotes the number of ways of arranging across k trunks, u_p busy channels on the first link, u_l busy channels on the second link, with u_c channels among them being occupied by calls that continue from the first link to second, such that V_p trunks are busy on the first link, V_l trunks are busy on the second link with V_c among them busy on both the links, and T_a trunks being available on the two-link path. $A_k(u_p, u_l, u_c)$ denotes all possible ways of arranging across k trunks, u_p busy channels on the first link, u_l busy channels on the second link with u_c channels among them being occupied by calls that continue from the first link to second. $A_k(u_p, u_l, u_c)$

is recursively computed as:

$$A_k(u_p, u_l, u_c) = \sum_{z=0}^{\min(S, u_c)} \sum_{x=z}^{\min(S, u_p)} \sum_{y=z}^{\min(S, u_l)} A_1(x, y, z) A_{k-1}(u_p - x, u_l - y, u_c - z) \quad (22)$$

where $0 \leq u_p \leq kS$, $0 \leq u_l \leq kS$, and $0 \leq u_c \leq \min(u_p, u_l)$. The definition of $A_1(x, y, z)$ depends on the nature of switch.

$N_k(V_p, V_l, V_c, T_a | u_p, u_l, u_c)$ (written as $N_k(\cdot)$ for short due to space constraints) is assigned 0 if any of the following conditions hold true:

- $\{V_p, V_l, V_c, T_a, u_p, u_l, u_c\} < 0$
- $\{V_p, V_l, V_c, T_a\} > k$
- $\{u_p, u_l\} > kS$ or $u_c > \min(u_p, u_l)$
- $u_p < V_p S$ or $u_l < V_l S$

Otherwise, it is computed recursively under one of the following four cases, as described in Section IV, Fig. 6:

Case 1: If $V_c > 0$

The required probability is obtained by conditioning on a trunk being busy on both the links.

$$N_k(\cdot) = \frac{k}{V_c} \sum_{z=0}^S A_1(S, S, z) N_{k-1}(V_p - 1, V_l - 1, V_c - 1, T_a | u_p - S, u_l - S, u_c - z) \quad (23)$$

Case 2: If $V_c = 0, V_p > 0$

The required probability is obtained by conditioning on a trunk being busy on the first link but free on the second link.

$$N_k(\cdot) = \frac{k}{V_p} \sum_{z=0}^{\min(S-1, u_c)} \sum_{y=z}^{\min(S-1, u_l)} A_1(S, y, z) N_{k-1}(V_p - 1, V_l, V_c, T_a | u_p - S, u_l - y, u_c - z) \quad (24)$$

Case 3: If $V_c = 0, V_p = 0, V_l > 0$

The required probability is obtained by conditioning on a trunk being free on the first link but busy on the second link.

$$N_k(\cdot) = \frac{k}{V_l} \sum_{z=0}^{\min(S-1, u_c)} \sum_{x=z}^{\min(S-1, u_p)} A_1(x, S, z) N_{k-1}(V_p, V_l - 1, V_c, T_a | u_p - x, u_l - S, u_c - z) \quad (25)$$

Case 4: If $V_c = 0, V_p = 0, V_l = 0$

The required probability is obtained by conditioning on a trunk being free on both the links. Two possible cases need to be considered: (1) the trunk is available on the two-link path or (2) the trunk is not available on the two-link path. Let $B_1(x, y, z)$ denote the number of ways of arranging on a trunk, x busy channels on the first link, y busy channels on the second link, with z channels among them being occupied by calls that continue from the first link to second, such that the trunk is not available on the two-link path. Similarly, let $F_1(x, y, z)$ denote the arrangement of the busy channels on a trunk such that the trunk is available on the two-link path. It can be observed that $F_1(x, y, z) + B_1(x, y, z) = A_1(x, y, z)$. $N_k(\cdot)$ can then be computed as:

$$N_k(\cdot) = \sum_{z=0}^{\min(S-1, u_c)} \sum_{x=z}^{\min(S-1, u_p)} \sum_{y=z}^{\min(S-1, u_l)} [F_1(x, y, z) N_{k-1}(V_p, V_l, V_c, T_a - 1 | u_p - x, u_l - y, u_c - z) + B_1(x, y, z) N_{k-1}(V_p, V_l, V_c, T_a | u_p - x, u_l - y, u_c - z)] \quad (26)$$

The starting point of the recursion (for $k = 1$), denoted by $N_1(V_p, V_l, V_c, T_a | u_p, u_l, u_c)$, is assigned 0 if any of the following conditions hold true:

1. $V_p = 0$ and $u_p = S$
2. $V_l = 0$ and $u_l = S$
3. $V_c = 0$ and $\min(u_p, u_c) = S$

Otherwise, it is defined in terms of $B_1(u_p, u_l, u_c)$ and $F_1(u_p, u_l, u_c)$ as,

$$N_1(\cdot) = \begin{cases} F_1(u_p, u_l, u_c) & \text{if } T_a = 1 \text{ and} \\ & V_p = V_l = V_c = 0 \\ B_1(u_p, u_l, u_c) & \text{if } T_a = 0 \\ 0 & \text{otherwise.} \end{cases} \quad (27)$$

The definitions of $A_1(u_p, u_l, u_c)$, $B_1(u_p, u_l, u_c)$, and $F_1(u_p, u_l, u_c)$ depend on the switch architecture.

C. Example switch models

Two kinds of switches are modeled in this section: space-only switch and full-permutation switch. For a space-only switch, channel continuity constraint is enforced by the switch. Hence, a call continuing from the first link to second occupies the same channel at the input and output of the switch. Note that although the switch is space-only, the switching provided by the node is channel-space due to the full-channel interchanger at the input of the node. A full-permutation switch, on the other hand, can switch any free channel at the input to any free channel at the output. For a trunk with S channels, $A_1(u_p, u_l, u_c)$ and $B_1(u_p, u_l, u_c)$ for the two switch models are defined as below:

Space-only switch:

$$A_1(u_p, u_l, u_c) = \begin{cases} \binom{S}{u_p} \binom{u_p}{u_c} \binom{S-u_c}{u_l-u_c} & \text{if } 0 \leq u_p, u_l \leq S \\ & \text{and } u_c \leq \min(u_p, u_l) \\ 0 & \text{otherwise.} \end{cases} \quad (28)$$

$$B_1(u_p, u_l, u_c) = \begin{cases} \binom{S}{u_p} \binom{u_p}{u_c} \binom{u_p-u_c}{S-u_l} & \text{if } 0 \leq u_p, u_l \leq S \\ & u_c \leq \min(u_p, u_l), \text{ and} \\ & u_p + u_l - u_c \geq S \\ 0 & \text{otherwise} \end{cases} \quad (29)$$

Full-permutation switch:

$$A_1(u_p, u_l, u_c) = \begin{cases} \binom{S}{u_p} \binom{S}{u_l} & \text{if } 0 \leq u_p, u_l \leq S \\ & \text{and } u_c \leq \min(u_p, u_l) \\ 0 & \text{otherwise.} \end{cases} \quad (30)$$

$$B_1(u_p, u_l, u_c) = \begin{cases} \binom{S}{u_p} \binom{S}{u_l} & \text{if } (u_p = S \text{ or } u_l = S) \\ & \text{and } u_c \leq \min(u_p, u_l) \\ 0 & \text{otherwise.} \end{cases} \quad (31)$$

It can be observed that the analytical models proposed earlier in the literature can be derived from this generalized model as:

- $K = W; S = 1; \gamma_c = 0$; [3], [4]
- $K = W; S = 1$; [6]
- $K = W; S = T; \gamma_c = 0$; full-permutation switch [12]
- $K = W; S = F$; full-permutation switch [9]

V. PERFORMANCE EVALUATION

The blocking performance of a multi-wavelength TDM switched network is analyzed in this section. Each link has 20 time slots (channels). Four combinations of number of wavelengths (trunks) and time slots are considered: (1) $W = K = 20, T = S = 1$; (2) $W = K = 1, T = S = 20$; (3) $W = K = 2, T = S = 10$; and (4) $W = K = 4, T = S = 5$. Each wavelength is treated as a trunk. Hence, no wavelength conversion is assumed. However, the second case with a full-permutation switch can be treated as any combination of wavelength and time slots with full-wavelength conversion, time slot interchange, and full-permutation switching.

A node that views a link as K trunks with S channels per trunk is referred to as a $K \times S$ node. A node that employs full-permutation switching is denoted by FP and that which provides time-space (channel-space) switching is denoted by CS.

Three kinds of network topologies are considered for performance evaluation:

1. a 25-node uni-directional ring network ($\gamma_c = 0.92$)
2. a 25×25 bi-directional mesh-torus network ($\gamma_c = 0.31$)
3. a 10-dimensional hypercube network ($\gamma_c = 0.09$)

The networks are assumed to employ shortest-path routing. If more than one shortest path is available, one of them is chosen at random. The path length distribution, $P(z)$, and the number of exit links, E , for the three networks are given below.

1. Uni-directional ring network with N nodes:

$$P(z) = \frac{1}{N-1} \quad 1 \leq z \leq N-1. \quad (32)$$

$$E = 1 \quad (33)$$

2. $M \times M$ bi-directional network (if M is odd):

$$P(z) = \begin{cases} \frac{4z}{M^2-1} & \text{if } 1 \leq z \leq \frac{M-1}{2} \\ \frac{4(M-z)}{M^2-1} & \frac{M-1}{2} < z \leq M-1 \end{cases} \quad (34)$$

$$E = 3 \quad (35)$$

3. n -dimensional hypercube ($N = 2^n$):

$$P(z) = \frac{1}{N-1} \binom{n}{z} \quad 1 \leq z \leq n \quad (36)$$

$$E = n-1 \quad (37)$$

Fig. 9 shows the blocking performance with varying link load for a 25-node uni-directional ring network. The performance obtained by time-space and full-permutation nodes are

almost the same in this network. It can be also be observed that a maximum of two orders of magnitude performance gain can be achieved by employing full-permutation switching. The maximum performance gain that can be achieved by switching depends on the correlation factor in the network. As the ring network has a very high correlation, a maximum of only two orders of performance improvement is possible.

Fig. 10 shows the blocking performance for a 25×25 bi-directional mesh-torus network. At low loads (1 Erlang), the performance gain obtained by time-space and full-permutation nodes over a node with neither time-slot interchangers nor wavelength converters are approximately 10 and 12 orders of magnitude, respectively. At high loads (7 Erlangs), the blocking performance of the time-space and full-permutation nodes are lower by 1 and 3 orders of magnitude, respectively as compared to the performance obtained with nodes not employing time-slot interchange and wavelength conversion. Such a high performance gain, especially under low link loads, indicates the effectiveness of switching in networks with moderate link correlation.

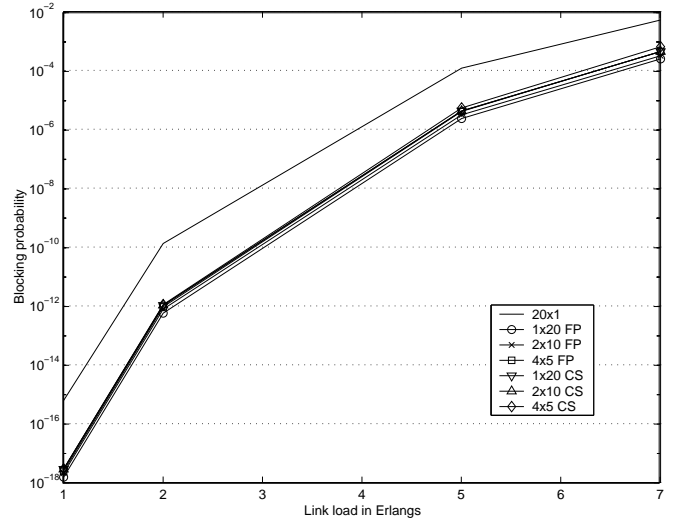

Fig. 9. Blocking probability versus link load for a 25-node uni-directional ring network.

Fig. 11 shows the blocking performance for a 10-dimensional hypercube network. The performance trends observed in this network are similar to that observed in a mesh-torus network. At low loads (1 Erlang), performance gain of upto 6 and 8 orders of magnitude can be obtained with time-space and full-permutation nodes, respectively over nodes that do not employ time-slot interchange and wavelength conversion. However, at high loads (7 Erlangs), the performance gain obtained reduces to 1 and 3 orders of magnitude for time-space and full-permutation switches, respectively.

It can also be observed that the performance offered by a 1×20 , 2×10 , and 4×5 full-permutation switches are almost the same. However, for a given capacity of a link, the switching speed of a 1×20 switch has to be 4 times higher than that of a 4×5 switch. On the other hand, a 4×5 CS switch (4 wavelengths with 5 time slots per wavelength) requires four sets transmitters and receivers, although each of them could work at lower speeds. Also, the performance offered by their respective

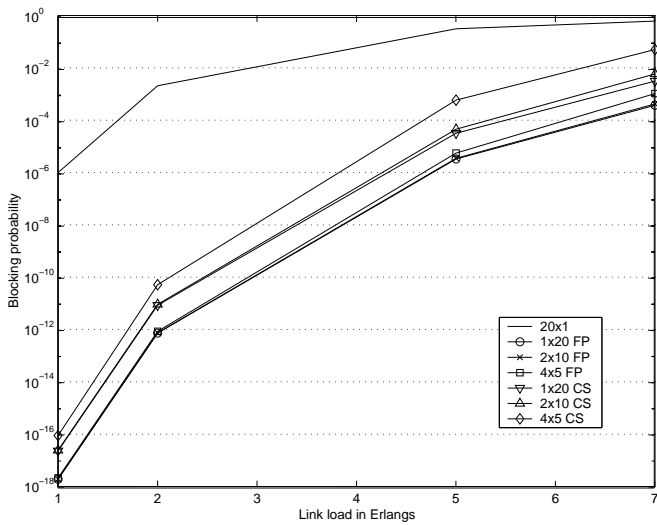

Fig. 10. Blocking probability versus link load for a 25x25 bi-directional mesh-torus network.

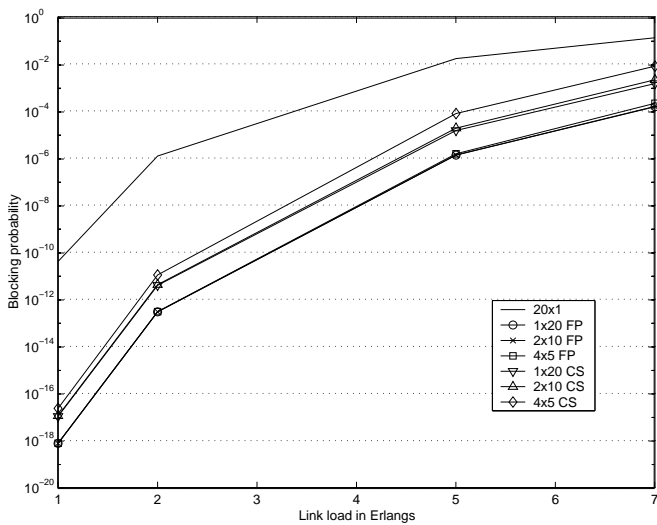

Fig. 11. Blocking probability versus link load for a 10-dimensional hypercube network.

time-space switches are within two-orders of magnitude difference, indicating that a significant improvement in performance can be achieved by employing time-space switches.

The performance results show that switching is effective in networks with low or medium link correlation achieving high performance gain. Also, in such networks, a significant performance gain is achieved with just a time-space switch, thus indicating the feasibility of realizing optical time switched networks in the near future offering good performance with simple switch architectures.

VI. CONCLUSION

The concept of trunk switched network is proposed in this paper to facilitate modeling and analysis of networks with heterogeneous node architectures. An analytical model for evaluating the blocking performance of a class of trunk switched networks is also developed. Using the analytical model, it is shown that a significant performance gain can be achieved with

a time-space switch with no wavelength conversion in a multi-wavelength TDM switched network.

The scope of the analytical model presented in this paper is limited to homogeneous TSN's. However, the analysis can be extended to heterogeneous TSN's by mapping the trunk distribution viewed by a node employing one switch architecture to that viewed by a node employing another switch architecture. This mapping is currently being investigated for a general trunk definition.

ACKNOWLEDGEMENTS

The authors would like to thank Dr. Mani Mina, Adjunct Faculty, Department of Electrical and Computer Engineering, Iowa State University, for his valuable comments and suggestions in improving the quality of the paper.

REFERENCES

- [1] R.A. Barry and P.A. Humblet, "Models of blocking probability in all-optical networks with and without wavelength changers," *IEEE Journal of Selected Areas in Communications*, vol. 14, no. 5, pp. 858–867, June 1996.
- [2] A. Birman, "Computing approximate blocking probabilities for a class of all-optical networks," in *Proceedings of IEEE INFOCOM'95*, April 1995, pp. 651–658.
- [3] M. Kovacevic and S. Acampora, "On wavelength translation in all-optical networks," in *Proceedings of IEEE INFOCOM'95*, April 1995, pp. 413–422.
- [4] M. Kovacevic and S. Acampora, "Benefits of wavelength translation in all-optical clear-channel networks," *IEEE Journal of Selected Areas in Communications*, vol. 14, no. 5, pp. 868–880, June 1996.
- [5] K. -C. Lee and V. O. K. Li, "A wavelength-convertible optical network," *Journal of Lightwave Technology*, vol. 11, no. 5, pp. 962–970, May-June 1993.
- [6] S. Subramaniam, M. Azizoglu, and A.K. Somani, "All-optical networks with sparse-wavelength conversion," *IEEE/ACM Transactions on Networking*, vol. 4, no. 4, pp. 544–557, August 1996.
- [7] R. Ramaswami and G. Sasaki, "Multiwavelength optical networks with limited wavelength conversion," *IEEE/ACM Transactions on Networking*, vol. 6, no. 6, pp. 744–754, December 1998.
- [8] T. Tripathi and K.N. Sivarajan, "Computing approximate blocking probabilities in wavelength-routed all-optical networks with limited-range wavelength conversion," in *Proceedings of IEEE INFOCOM'99*, March 1999, vol. 1, pp. 329–336.
- [9] L. Li and A.K. Somani, "A new analytical model for multi-fiber WDM networks," in *Global Telecommunications Conference, GLOBECOM'99*, 1999, vol. 1B, pp. 1007–1011.
- [10] N. Wauters and P. Demeester, "Is wavelength conversion required?," in *IEEE International Conference on Communications'96 Workshop on WDM Management*, June 1996.
- [11] N. Wauters and P. Demeester, "Wavelength conversion in optical multi-wavelength multi-fiber transport networks," *International Journal of Optoelectronics*, vol. 11, no. 1, pp. 53–70, January/February 1997.
- [12] J. Yates, J. Lacey, and D. Everitt, "Blocking in multiwavelength TDM networks," in *4th International Conference on Telecommunication Systems, Modeling, and Analysis*, March 1996, pp. 535–541.
- [13] J. -W. Kang, J. -S. Kim, C. -M. Lee, E. Kim, and J. -J. Kim, "1x2 all-optical switch using photochromic-doped waveguides," *Electronics Letters*, vol. 36, no. 19, pp. 1641–1643, September 2000.
- [14] C. Kim, D. A. May-Arrioja, P. Newman, and J. Pamulapati, "Ultrafast all-optical multiple quantum well integrated optic switch," *Electronics Letters*, vol. 36, no. 23, pp. 1929–1930, November 2000.
- [15] C. De Matos, M. Pugno, and A. Le Corre, "Ultrafast coherent all-optical switching in quantum-well semiconductor microcavity," *Electronics Letters*, vol. 36, no. 1, pp. 93–94, January 2000.
- [16] D. K. Hunter and D. G. Smith, "New architectures for optical TDM switching," *IEEE/OSA Journal of Lightwave Technology*, vol. 11, no. 3, pp. 495–511, March 1993.
- [17] H. F. Jordan, D. Lee, K. Y. Lee, and S. V. Ramanan, "Serial array time slot interchangers and optical implementations," *IEEE Transactions on Computers*, vol. 43, no. 11, pp. 1309–1318, November 1994.
- [18] D. Bertsekas and R. Gallager, *Data Networks*, Prentice Hall, 1992.