

Sparsely Hubbed Light-Trail Grooming Networks

Srivatsan Balasubramanian, Arun K. Somani, and Ahmed E. Kamal
Department of Electrical and Computer Engineering
Iowa State University, Ames, IA 50011
E-mail: {vatsan, arun, kamal}@iastate.edu

Abstract—Recently, a new architecture called light-trails has been proposed that provides a novel control and management solution to address IP-centric issues at the optical layer. By inclusion of simple hardware that performs drop and continue functionality, overlaid with a light-weight control protocol, light-trails enable efficient sharing of network resources, improve bandwidth utilization and minimize network costs. Due to power budget constraints in such networks, it may not always be possible to have end to end communication in pure optical domain and requests may be required to traverse multiple intermediate transit points called hub nodes before reaching the final destination. The hub nodes need to be equipped with special hardware for switching and grooming connections. We investigate the problem of designing networks where such hubs are sparsely located. We show through our simulation results that by carefully designing heuristics for hub node placement and trail routing, it is possible to achieve high throughput with minimal number of hub nodes.

The unprecedented growth of internet traffic and rapid advancements in the optical transport technologies have fueled the Internet transport infrastructure to evolve towards a model of high speed IP routers interconnected by intelligent optical networks. As a solution to providing high resource utilization and sub-wavelength support, we discuss light-trail technology [1]. The goal of light-trails is to eliminate active switching, and leverage statistical resource multiplexing to address the growing demands placed on WDM networks. A light-trail is similar to lightpath in that, it requires the establishment of a unidirectional optical circuit between the source and destination. The key difference is that some intermediate nodes can also receive and transmit data on the same channel in a time multiplexed manner.

Figure 1(b) shows a four node uni-directional light-trail [1]. A simple medium access control protocol, discussed in [2], can coordinate communication among nodes in the trail. When a source transmits data on a trail, the signal traverses all nodes downstream to it on the trail. At every node, the signal passes through a light-trail access unit (LAU) that consists of a splitter, a shutter and a combiner that enables drop-and-continue functionality. At the splitter, a part of the incoming signal power is tapped by the receiver for local processing while the rest of the optical signal passes to the shutter. The shutter is a mirror-based optical attenuator that is configured to either block or let the wavelength pass through. If the node is the last or the first node on the trail, the shutter is configured in the off position, isolating this wavelength from the rest of the network. For all intermediate nodes on the trail, the shutter is in the on/pass-through position, letting the signal

pass through. If the signal is not blocked by the shutter, it traverses the combiner before exiting the node. The combiner allows the intermediate node to insert its packets on the trail according to the light-trail access strategy. The shutters are not reconfigured dynamically for every packet but is done on a longer time scale. This alleviates the requirement for high speed switching and yet accommodates dynamic traffic by setting up new trails that vary slowly and tearing down unused trails in a distributed manner. Readers are referred to [5] for a detailed description of light-trail switch architecture and network design. Figure 1(c) shows a complete light-trail network solution.

Consider a network topology as a directed graph $G(V,E)$, with V as the vertex set and E as the edge set. Let a light-trail instance, which is just a simple path in a graph, be defined by $LT_t = \{v_1, v_2, v_3\}$ such that $v_1, v_2, v_3 \in V$ and $(v_1, v_2), (v_2, v_3) \in E$. Let R be the request matrix that denotes the value of the request between any node pair. A light-trail is a circuit that carries multiple requests subject to the following constraints:

Containment Constraint: A light-trail can support any request (v_i, v_j) if v_j is downstream of v_i in LT_t . That is, LT_t can possibly support the requests given by the set $LT_t^r = \{(v_1, v_2), (v_1, v_3), (v_2, v_3), \}$ If a similar set were defined for a lightpath between v_1 and v_3 , it would be $LP_p^r = \{v_1, v_3\}$

Capacity Constraint: The sum of request values supported by a light-trail is at most the capacity of a wavelength (C). If $C = 5$, $R_{v_1, v_2} = 3$, $R_{v_1, v_3} = 3$, $R_{v_2, v_3} = 2$, then LT_t can support one of the following: $\{(v_1, v_2), (v_2, v_3)\}$, $\{(v_1, v_3), (v_2, v_3)\}$, $\{(v_1, v_2)\}$, $\{(v_1, v_3)\}$, or $\{(v_2, v_3)\}$.

The other constraints may include:

Non-bifurcation Constraint: A connection cannot be split across multiple trails. This aspect gains significance in light of the fact that traffic reassembly is complex, expensive and introduces undesirable jitter at the application layer.

Trail Length Constraint: The data signal incurs a power loss on every node of the trail and due to power constraints, the trail size, defined as the number of hops in LT_t , may be limited.

The work in [1] and [2] introduced light-trails as a solution for handling IP-centric traffic in the MAN/WAN setting. A prototype implementation of the light-trail testbed was described in [3]. The mesh network design problem was discussed in [4] and later extended in [5]. The work that is closest to our current study are [4] and [6]. Sparse grooming problem in the context of lightpath networks was studied in [6]. Grooming is a well researched topic and a survey of progress in this research area can be found in [7], [8], [9].

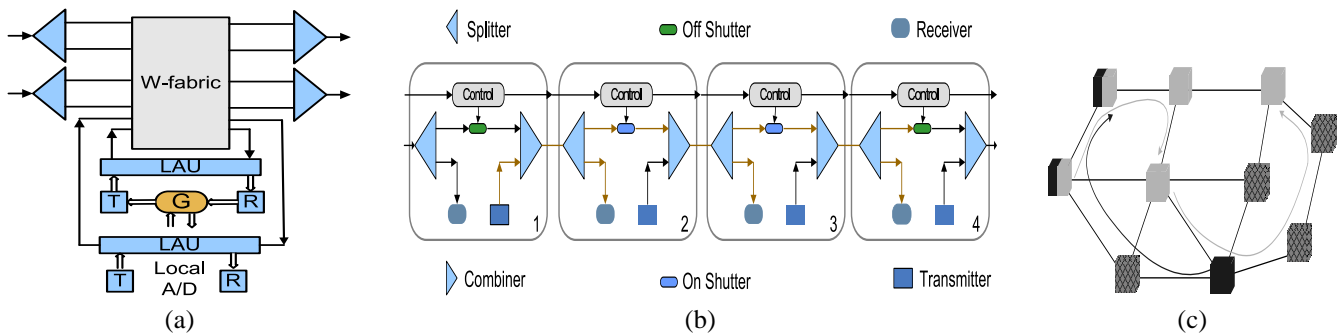

Fig. 1. (a) Switch architecture for the hub. W-fabric is the wavelength crossconnect fabric and G fabric hubs connections (b) Node architecture. Data transfer from node 1 to node 4 in a light-trail. The splitter-shutter-combiner constitute the LAU. The arrows in lighter shade show packets transmitted by node 1 to nodes downstream.(c) An example light-trail network. A node shaded the same color as the trail passing through it indicates that this node is active on that trail. A node with multiple shades is active on multiple trails, and a node with different shade from the wavelength passing through it is inactive on that trail.

The purpose of our study is to investigate the design problem of light-trail networks with sparse hub nodes, which, to the best of our knowledge, has not been explored earlier. The rest of the paper is organized as follows: The first section provides the motivation for current work and defines the multi-hopping problem in light-trail networks. Section II presents the ILP formulation. Section III proposes heuristics for hub node selection and trail routing. Simulation results are discussed in Section IV, and conclusions are provided in section V.

I. PROBLEM MOTIVATION

In WDM networks, the client signals are likely to be of multiple granularities and have sub-wavelength capacity requirements. Traffic grooming (or e-grooming) packs low speed connections onto high speed channels to achieve efficient resource sharing and minimize network costs. Light-trails also provide grooming, but in the optical layer (or o-grooming) and by careful network design, bandwidth utilization can be greatly improved [1], [5]. As mentioned earlier, a light-trail $\{v_1, v_2, v_3\}$ requires only one wavelength to carry requests (v_1, v_2) , (v_1, v_3) and (v_2, v_3) , provided the sum of their traffic is at most C . O-grooming has a strong appeal since e-grooming is associated with complexity, delay, scalability and cost concerns with increasing line speeds. For a detailed discussion on the motivation and the cost-effectiveness of the light-trail based network solution, readers are referred to the study in [5]. The resource sharing in light-trails is achieved as a result of drop and continue functionality and a simple overlaid control protocol. However, the new hardware introduces additional losses to the signal (about 8 dB per node). With lossy optical components, the signals may not always be carried end to end in the pure optical form. Even if compensation on every node is provided using amplifiers, due to amplifier noise, the signal may be degraded and not be able to traverse beyond a certain hop limit which we call the trail length limit (δ). In this case, it becomes necessary for a request to traverse multiple intermediate trails to reach the final destination.

Let $d_{i,j}$ and $R_{i,j}$ denote the distance and traffic between nodes i and j respectively. If $d_{i,j} > \delta$, pair (i,j) is said to be *physically blocked* and $R_{i,j}$ cannot be carried by a direct trail

from i to j . There may exist an intermediate node k , such that $d_{i,k} \leq \delta$, $d_{k,j} \leq \delta$, in which case, k is said to be in the *proximity* of (i,j) . If $R_{i,j}$ is first carried from node i to node k on one trail and then shifted to another trail from node k to node j , then we define k to be the *hub* for pair (i,j) . In a static scenario, this multi-hop model is equivalent to a *traffic matrix rearrangement*, where the original traffic matrix is modified to obtain a new traffic matrix. That is, $R_{i,k}^n = R_{i,k}^o + R_{i,j}^o$, $R_{k,j}^n = R_{k,j}^o + R_{i,j}^o$ and $R_{i,j}^n = 0$, where the superscripts o and n refer to the old and new values respectively. The hub node (H-node) is just another node in the network, but equipped with special grooming hardware required to act as transit point for the physically blocked traffic. Figure 1(a) illustrates the hub switch architecture. The figure shows two kinds of ports - one that supports light-trail statistical o-grooming through the LAU and the other that supports circuit-switched e-grooming through the G-fabric. Non-hub nodes contain only the first kind of port and not the second kind. Access in a light-trail network can happen only through an LAU even for circuit switched grooming.

The work in [4] allows every physically blocked pair (i,j) to choose a random node k in its proximity as its hub and hence requires all nodes to be grooming capable leading to significant network costs. In our work, we carefully design the H-node placement so that the total number of H-nodes is minimized while still not compromising on network throughput. It is important to emphasize here that while e-grooming in lightpaths is required to improve bandwidth utilization, such a functionality is already offered at the optical layer in light-trails. The hub nodes simply provide transit points for multi-hop traffic and we focus on minimizing such nodes.

We give a formal description of the sparse hubbing problem here. Given a network topology $G(V,E)$, where V is the node set, E is the link set, C is the capacity of wavelength, and R is the traffic matrix representing sub-wavelength traffic, design a network so as to optimize one of the following objectives: (1) For a given number of H-nodes and wavelengths, maximize the network throughput. (2) Carry all the traffic while minimizing the number of wavelengths and H-nodes used. The main focus of the current work is on the second objective.

II. ILP FORMULATION

We formulate an integer linear program to solve the sparse hubbing problem. We make the following assumptions in our study. There is no wavelength conversion capability. There exists at most one fiber link between any node pair. Individual connection requests do not exceed the wavelength capacity though aggregate traffic between a node pair can be of arbitrary value. Tunable transmitters and wide bandwidth receivers are assumed to be present on all the nodes. A connection request should never be split across multiple routes both on the physical and on the logical topology. Each connection C_n , $1 \leq n \leq K$, is an ordered pair (s,d,p,y) which refers to the p -th OC- y connection from node s to node d . We define C_λ to be the cost of maintaining a wavelength in the network and C_h to be the cost of a hub node. We describe the rest of our notation below.

N - number of nodes in the network (data)
 C - capacity of a wavelength (data)
 W - number of wavelengths on each link of capacity C (data)
 LT - set of possible light-trails in the network (data)
 LT_t - an instance of a light-trail $LT_t \in LT$ (data)
 LT_t^r - set of requests that can be supported by LT_t based only on the containment constraint (data)
 $LT_t^{i,j}$ - 1 if trail LT_t traverses link (i,j) , 0 otherwise (data)
 R_{c_n} - traffic request value of connection c_n (data)
 $t = 1..||LT||$ - number assigned to each light-trail(index)
 $\lambda = 1..W$ - number assigned to each wavelength (index)
 $m, n = 1..K$ - number of connections in the network (index)
 $i, j, s, d, = 1..N$ - nodes in the network (index)
 α - a very large number (say, 10000) (data)
 $\phi_{i,j}^{c_n}$ - 1 if c_n is carried by node pair (i,j) , 0 otherwise (variable)
 Φ^{c_n} - 1 if c_n is carried by the network, 0 otherwise (variable)
 T_t^λ - 1 if wavelength λ is assigned to trail t , 0 otherwise (variable)
 TX_t^i - 1 if node i on trail t needs a transmitter, 0 otherwise (variable)
 RX_t^i - 1 if node i on trail t needs a receiver, 0 otherwise (variable)
 $X_{i,j,t}^{c_n}$ - 1 if node pair (i,j) carries c_n on trail t , 0 otherwise (variable)
 χ_i - 1 if a node is hub capable, 0 otherwise (variable)
 U_λ - 1 if wavelength λ is used, 0 otherwise (variable)
 N_h - number of hub nodes (variable)
 N_λ - number of wavelengths used in the network (variable)
 T_t - number of instance of trail LT_t (variable)

A. Maximize Throughput

$$\text{Maximize } \sum_{c_n} \Phi^{c_n} \quad (1)$$

Subject to constraints

$$\sum_j \phi_{s,j}^{c_n} = \Phi^{c_n} \quad \forall c_n \quad (2)$$

$$\sum_j \phi_{j,d}^{c_n} = \Phi^{c_n} \quad \forall c_n \quad (3)$$

$$\sum_j \phi_{j,i}^{c_n} = \sum_{j,j \neq s} \phi_{i,j}^{c_n} \quad \forall c_n, \forall i \quad (4)$$

$$\sum_j \phi_{j,s}^{c_n} = 0 \quad \forall c_n \quad (5)$$

$$\sum_j \phi_{d,j}^{c_n} = 0 \quad \forall c_n \quad (6)$$

$$\chi_i \geq \sum_j \sum_{c_n} \phi_{i,j}^{c_n} / \alpha \quad \forall i, i \neq s \quad (7)$$

$$N_h \geq \sum_i \chi_i \quad (8)$$

$$\sum_t X_{i,j,t}^{c_n} = \phi_{i,j}^{c_n} \quad \forall c_n, \forall i, (i,j) \in LT_t^r \quad (9)$$

$$\sum_{i,j \in LT_t^r} \sum_{c_n} R_{c_n} X_{i,j,t}^{c_n} \leq T_t C \quad \forall t \quad (10)$$

$$\sum_\lambda T_t^\lambda = T_t \quad \forall t \quad (11)$$

$$\sum_t T_t^\lambda \leq 1 \quad \forall \lambda, \{t : LT_t^{p,q} = 1, \forall (p,q) \in E\} \quad (12)$$

$$U_\lambda \geq \sum_t T_t^\lambda / \alpha \quad \forall \lambda \quad (13)$$

$$N_\lambda \geq \lambda U_\lambda \quad \forall \lambda \quad (14)$$

$$TX_t^i \geq X_{i,j,t}^{c_n} \quad \forall c_n, \forall t, \forall i, \forall (i,j) \in LT_t^r \quad (15)$$

$$\sum_t TX_t^i \leq TX_i \quad \forall i \in LT_t \quad (16)$$

$$RX_t^i \geq X_{j,i,t}^{c_n} \quad \forall c_n, \forall t, \forall i, \forall (j,i) \in LT_t^r \quad (17)$$

$$\sum_t RX_t^i \leq RX_i \quad \forall i \in LT_t \quad (18)$$

$$X_{i,j,t}^{c_n}, \phi_{i,j,t}^{c_n}, \chi_i, U_\lambda, \Phi^{c_n}, T_t^\lambda \in (0, 1)$$

$$TX_t^i, RX_t^i, N_h, N_\lambda, T_t \in I \quad (19)$$

The above formulation accepts set of possible trails (LT) in the network as input and maximizes throughput. Equation (1) maximizes the carried connection. Equation (2), (3), (4), (5) and (6) route all the accepted connections using the flow conservation on the source, destination and any intermediate node. Equation (7) identifies the hub nodes and equation (8) counts the total number of hub nodes in the network. Equation (9) determines the physical route (specified by the trail) on

which the connections are carried. Equation (10) allows a wavelength to be packed only up to its maximum capacity and equation (11) assigns a wavelength to each trail. Equation (12) prevents wavelength collision between trails sharing a link while equation (13) keeps track of the wavelengths that are used in the network and equation (14) counts the total number of wavelengths required. A node may have a trail traverse it but may still not be active on it since the signal bypasses the LAU on that node [5]. Equations (15) and (17) identify the trails on which the node i are active for transmission and reception respectively. Equations (16) and (18) ensure that the number of communication equipments required do not exceed the resources provisioned.

B. Minimize network costs

If the objective function in (1) is replaced with the new function **Minimize** $C_\lambda N_\lambda + C_h N_h$, and if $\Phi^{c_n} = 1 \forall c_n$, is set as an additional constraint, while retaining the rest, the new formulation optimizes cost of a sparsely hubbed network, while accepting all the traffic. If the trail length is constrained, only trails of restricted length may be provided as input (LT) to the ILP. All the physically blocked requests are automatically and optimally assigned hubs by the ILP. If N_h is removed from the objective function, it reflects light-trails with full hubbing capability and now if $N_h = 0$ is introduced as an additional constraint, it models light-trails with no hubbing capabilities. If LP_p^r replaces LT_t^r in all the equations for the cost minimization formulation, the ILP solves for lightpaths with sparse grooming capabilities. Now, removing N_h from the objective function models lightpaths with full grooming and setting $N_h = 0$ as an additional constraint models lightpaths with no grooming capabilities. Similar extensions can be done for throughput maximization formulation to model lightpaths.

III. HEURISTICS

The ILP problem is computationally intractable and is not feasible for design of large networks. We propose heuristics to solve the sparse hubbing problem in such cases. For a given network topology, number of wavelengths and H-nodes, our heuristics work as follows. We first choose the nodes to be equipped with hubbing capabilities based on some selection criteria. We perform traffic matrix rearrangement and carry physically blocked connections through hub nodes (called hubbing). The connections are then routed on the physical topology using a trail routing heuristic. Finally, a first-fit wavelength assignment is done for each trail. We outline only the main steps of the heuristics due to space constraints.

A. H-node selection

We suggest three criteria to select H-nodes in the network.

1. Eccentricity criteria (EC): The eccentricity of a vertex in a graph is the longest of the shortest paths between the vertex and all the other points in the network. Nodes with low eccentricity values can be good H-node candidates.
2. Proximity criteria (PC): Find the number of physically

blocked (i,j) pairs such that a node k lies in the proximity of (i,j) and assign this as a rating for k . Nodes with high proximity rating can be good H-node candidates.

3. Random criteria (RC): H-nodes are randomly chosen.

B. Hubbing

The physically blocked node pairs are sorted in list B in the non-increasing order of their aggregate request values. The set of hub capable nodes (selected based on one of the above mentioned criteria) are ordered in list H. Consider the first node pair $(i,j) \in B$. Find all candidates $k \in H$ such that k lies in the proximity of (i,j) and there already exists some traffic from i to k and k to j . Make an entry for k in list S. The blocked node pair (i,j) is then hubbed by one or many of the candidate nodes in S since individual connections from (i,j) can traverse different paths to reach the destination. The hubbing heuristic rearranges traffic and tries to accommodate it within the surplus capacity of the existing trails and not open up a new trail unless absolutely required. This procedure is repeated for every (i,j) in list B until no further traffic rearrangement is possible. If there still exists some physically blocked pairs that are not rearranged, they remain blocked. A node pair (i,j) could be blocked because there may not exist any node in list H that lies in the proximity of this node pair. The rest of the rearranged requests are packed onto trails and routed subject to the wavelength availability constraint.

C. Trail routing and wavelength assignment

The trail routing and wavelength assignment heuristic used here is different from the one introduced in [5] since we deal with connections of multiple granularities subject to non-bifurcation constraints. The prime focus of the heuristic is to pack as many requests as possible onto a trail while still balancing the load on the links. It runs the Floyd Warshall's algorithm and finds the shortest path between all possible node pairs. The hubbing step ensures that most of the physically blocked pairs with non-zero traffic have their connections rearranged through the hub nodes. Based on the rearranged matrix, sort all the node pairs that are not physically blocked in the non-increasing order of their shortest path lengths in list L. The farthest node pairs in L are routed first. Multiple shortest paths are tried and a first-fit wavelength assignment is performed selecting the route that corresponds to the lowest wavelength index, since this minimizes congestion. In case of a tie, the trail that is maximally packed as described in [5] is chosen. The traffic matrix is updated to reflect the routed connections. The node pairs are scanned sequentially in L, and the process of identifying the next trail is repeated in a similar manner until no more trails can be routed because all requests have been routed or due to wavelength exhaustion.

IV. SIMULATION RESULTS

The ILP formulation in both the forms were solved using CPLEX 8.1.0 for the network shown in Figure V(a). The capacity of a wavelength is assumed to be OC-48. The requests between any node pair are of three granularities - OC-1,

OC-3 and OC-12. With probability p , a connection of each granularity is established between a node pair and we set $p = 0.5$ for the illustrative example in Figure 3. The number of such OC-1, OC-3 and OC-12 streams are uniformly distributed between (0,1), (0,1) and (2,3) units respectively.

For the throughput maximization ILP problem in light-trails with $\delta = 2$, if $N_h = 0$ is added as an additional constraint, only 389 units are carried for $W=3$ or more as shown in Figure 3(a). If we set $N_h=1$, all the traffic (413 units) can be supported for $W = 3$ or more. At $W=1$, only 306 units (about 74%) of the traffic is carried even when hub capable nodes are present in the network showing that wavelength is the bottleneck.

For the cost minimization ILP problem, we assume $C_\lambda=1$ and $C_h = 1$, and provide all possible paths as input. We find that lightpaths with no grooming requires 4 wavelengths whereas whereas lightpaths with full grooming require 3 wavelengths as shown in Figure 3(b). Lightpaths with sparse grooming requires only one grooming node and needs three wavelengths. This shows that sparse grooming can achieve performance close to full grooming. When light-trails with no trail length constraints are studied, no hubbing was required and still only 3 wavelengths were consumed. This suggests that multiplexing in trails achieve functionality equivalent to lightpath grooming in this network. When the trail length limit constraint is imposed and trails of length 2 are provided as input, all the traffic is still carried using 3 wavelengths while one node is designated as a hub node as shown in Figure 3(c).

We apply our heuristics to study the effect of sparse hubbing on a 25-node network shown in Figure V(b). The number of OC-1, OC-3 and OC-12 streams between a node pair are uniformly distributed as (0,12), (0,2) and (0,1) units respectively. We set $W = 13$, $\delta = 3$, and observe average throughput of the network as a function of the number of H-nodes in Figure 4(a) by running the simulation with 500 different traffic matrices having the above distribution. When $N_h = 0$, about 74 % of the traffic is carried while the rest are physically blocked. With only a few H-nodes, the throughput climbs steeply and reaches close to 100 %. We observe that the PC heuristic yields the best throughput followed by the EC heuristic. The RC heuristic performs the worst but they all converge to the same value as the number of H-nodes increase.

We study the average wavelength requirement by running the simulation for 2000 traffic matrices of above distribution in Figure 4(b). In this case, if we do not observe 100 % throughput, it is because of physically blocked node pairs and not because of wavelength exhaustion. We observe that EC heuristic yields the minimum number of wavelengths closely followed by the PC heuristic. The random heuristic, on an average, is unable to achieve 100 % throughput until about $N_h = 11$ (not shown in figure), while the other two yield 100 % throughput with only just one hub node. Since the hubs are randomly chosen in RC heuristic, hubs may not be available in the proximity of every physically blocked node pair. In both the PC and EC heuristic, the first node that is chosen corresponds to the center of the graph. Since the diameter is 6, and the center of the graph has the longest path of 3 from it,

the first chosen vertex is in the proximity of every physically blocked pair. If wavelength availability is not a bottleneck, it is the hub for all physically blocked pairs. Hence, 100 % throughput can be observed with just one hub node.

As wavelength requirements decrease with increase in number of hub nodes, it may be interesting to identify the exact number of hub nodes required for a given traffic scenario. We can identify the network cost similar to the approach in [6].

Define the ratio ρ ,

$$\rho = \frac{C_h}{C_\lambda}$$

The cost of the network C_n is

$$C_n = N_h \times C_h + N_\lambda \times C_\lambda = (N_h \times \rho + N_\lambda) \times C_\lambda$$

Normalizing the cost by C_λ ,

$$C_n = N_h \times \rho + N_\lambda \quad (20)$$

Figure 5(a) shows the cost of the network for various values of ρ . If the cost of the hub node is much larger than maintaining a wavelength, it may be better to operate with minimal number of hub nodes. For this specific example, if $\rho = 1$ or 2, the optimal cost is achieved at $N_h=5$ while for $\rho = 0.1$ or 0.2, the optimal cost is at $N_h=7$. The utilization of a wavelength for various values of trail sizes are shown in Figure 5(b). The load on x-axis corresponds to the parameter p described above. As p increases from 0 to 1, it can be seen that the wavelength utilization steadily increases and reaches about 82 % indicative of good packing by our heuristic. Heavier load at shorter δ is due to traffic rearrangement.

V. CONCLUSIONS

We studied the sparse hubbing problem in light-trail networks and showed how it is different from the lightpath grooming problem. We adopted a unified approach for ILP formulation that is applicable for both groomed-lightpath and hubbed-light-trail networks, and presented results for a test network. We introduced the light-trail hub node architecture, designed simple heuristics for H-node placement, traffic rearrangement and light-trail routing in the context of multiple granularity connections subject to non-bifurcation constraints. Our simulation results suggest that with only a small number of hub nodes, high network throughput and good wavelength utilization can be achieved. Our research also gives guidelines for deciding the network operation point based on network element costs. We reserve the study of dynamic traffic in light-trails and studying the effect of incorporating electronic traffic grooming functionality in the hub nodes as future work.

The reported research is funded in part by NSF under grant ANI-0087746 and ANI-0323374.

REFERENCES

- [1] A. Gumaste, and I. Chlamtac, *Light-trails: an optical solution for IP transport*, Journal of optical networking, Vol. 3, No.4, April 2004.
- [2] A. Gumaste, I. Chlamtac, *Light-trails: A novel conceptual framework for conducting optical communications*, Proceedings of HPSR 2003 Torino, Italy June 2003.

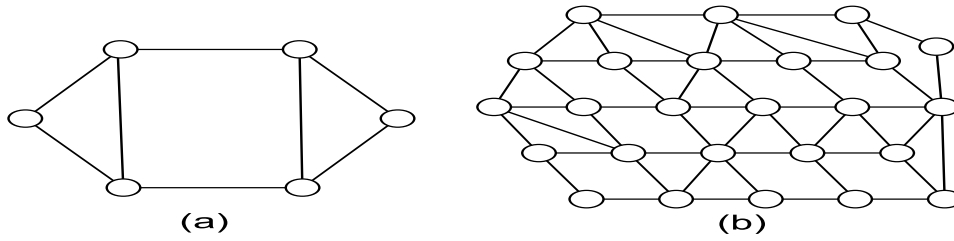

Fig. 2. Test networks used for simulations (a) six-node network for ILP, Diameter = 3 (b) 25 node network for heuristics, Diameter = 6.

N_h/W	3	2	1
0	389	365	292
1	413	402	306

(a)

	N_g	N_λ
LP + FG	6	3
LP + SG	1	3
LP + NG	0	4

(b)

	N_h	N_λ
LT + NH	0	3
LT + SH	1	3
LT + FH	6	3

(c)

Fig. 3. Results from ILP for the six-node network (a) Maximize throughput formulation with $\delta = 2$ (b) Minimize cost formulation for lightpaths. LP = lightpaths, SG = sparse grooming, FG = full grooming, NG = no grooming (c) Minimize cost formulation for light-trails. LT + NH = light-trails with no trail length constraints and no hubs, LT + SH = light-trails with sparse hub nodes, $\delta = 2$, LT + FH = light-trails with all nodes hub capable, $\delta = 2$.

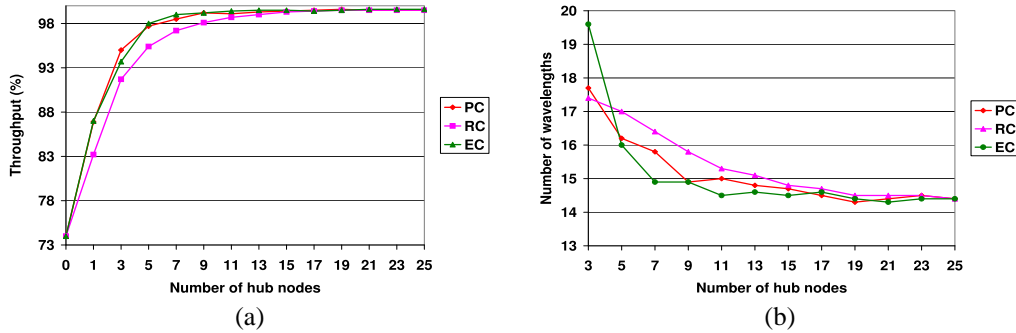

Fig. 4. (a) Network throughput as a function of the number of hub nodes for the 25 node network with $W = 13$, $\delta = 3$ (b) Wavelength requirements for 100% throughput (throughput is less for RC heuristic) at $\delta = 3$, as a function of the number of hub nodes for the 25 node network.

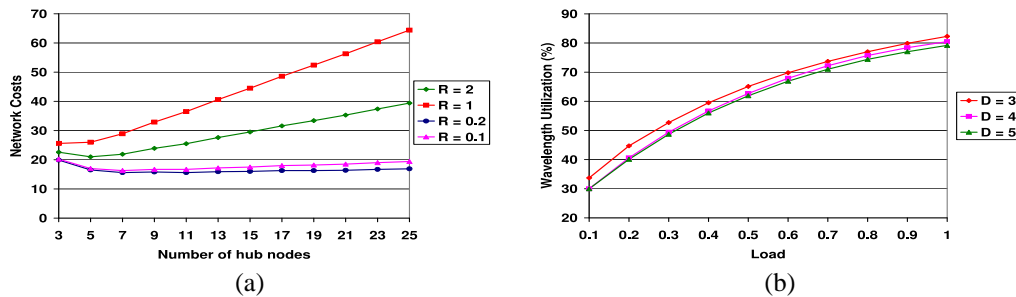

Fig. 5. (a) Network costs plot to determine the optimal number of hub nodes (b) Wavelength utilization as a function of load for varying trail length limits (D).

[3] N. VanderHorn, S. Balasubramanian, M. Mina, A.K. Somani, *Light-Trail Test Bed for IP-Centric Applications*, IEEE Communications Magazine-Special Issue on Optical Networking Testbeds: Experiences, Challenges and Future Directions, August 2005.

[4] J. Fang, W. He and A. K. Somani, *Optimal light-trail Design in WDM Optical Networks*, the proceedings of ICC 2004, vol.3, Paris, 2004.

[5] S. Balasubramanian, A.E. Kamal, A.K. Somani, *Network design for IP-Centric light-trail networks*, The Second International Conference on Broadband Networks, IEEE Broadnets 2005.

[6] K.Zhu, H.Zang, B. Mukherjee, *Design of WDM networks with sparse grooming capability*, IEEE Globecom 2002, Nov. 2002

[7] K.Zhu, B. Mukherjee, *Traffic grooming in an optical WDM mesh network*, IEEE Journal on selected areas in communications, Vol. 20, No.1, Jan. 2002

[8] K.Zhu, H.Zang, B.Mukherjee, *A comprehensive study of next-generation optical grooming switches*, IEEE Journal of selected areas in communications, Vol 21, No. 7, September 2002, and references therein.

[9] R. Dutta,G.N. Rouskas, *Traffic Grooming in WDM networks: Past and Future*, IEEE Network, Nov/Dec 2002, , and references therein.